

2 Port Low Profile PCI RS-422/485 Card

PCI2S485LP PCI2S485LP15

Packaging Contents

- 1 x PCI2S485LP/15 PCI Card
- 1 x DB9 Breakout cable
- 1 x Driver CD
- 1 x User Manual

System Requirements

- Available PCI or PCI-X port
- Microsoft Windows[®] 2000/XP/Vista, Linux[®]

Installation

WARNING! PCI cards, like all computer equipment, can be severely damaged by static electricity. Be sure that you are properly grounded before opening your computer case or touching your card. StarTech.com recommends that you wear an anti-static strap when installing any computer component. If an anti-static strap is unavailable, discharge yourself of any static electricity build-up by touching a large grounded metal surface (such as the computer case) for several seconds. Also, be careful to handle the card by its edges and not the gold connectors.

Hardware Installation

1. Turn your computer off and any peripherals connected to the computer (ie. Printers, external hard drives, etc.). Unplug the power cable from the rear of the power supply on the back of the computer.
2. Remove the cover from the computer case.
3. Locate an open PCI or PCI-X slot and remove the metal cover plate on the rear of the computer case.
4. Insert the card into the open PCI or PCI-X slot and screw the bracket to the rear of the case.
5. Place the cover back onto the computer.
6. Insert the power cable into the socket on the power supply.

Dip Switch Configuration

Mode	Switch 1	Switch 2	Switch 3	Switch 4
RS-485	ON	ON	OFF	OFF
RS-422	ON	ON	ON	ON

Driver Installation

Windows 2000/XP

1. When the Found New Hardware Wizard appears, click Next to continue.
2. Insert the Driver CD (included) into the CD/DVD-ROM drive. Select Search for the best driver for your device (recommended) then click on Next.
3. Select Specify the location... and type d:\Win2K \ XP (where d:\ designates the location of the CD/DVD-ROM drive). in the text box provided, and click Next.
4. Click on Next, then Finish.
5. Remove the Driver CD from the CD/DVD-ROM drive and re-start the computer when prompted.

Windows Vista

Once the computer has rebooted:

1. Insert the Driver CD (included) into the CD/DVD-ROM drive. At the Found New Hardware window, click on Locate and install driver software (recommended), and click Next on the screen that follows
2. When a message appears indicating that the publisher of the driver cannot be verified, please click on "Install this driver software anyway".
3. Once installation is complete, you will be notified that NetMos 98xx PCI Multi-I/O Controller has been installed successfully. Please repeat steps 2 and 3 as necessary.

Wiring Configuration

RS-485 (Transmitter is controlled automatically by ATTATM Hardware)

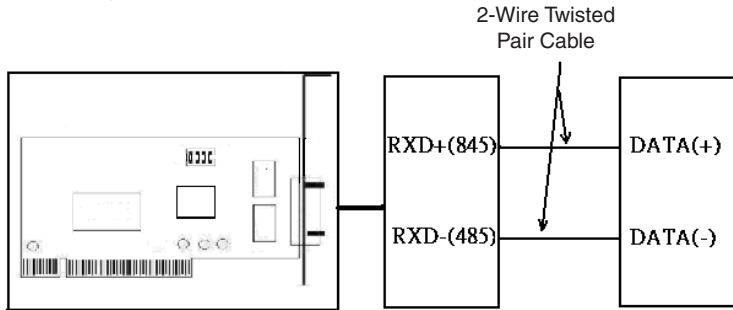

Please note: This card supports optional auto echo mode. If enabled, data sent to the RS-485 transmitter will be mirrored and simultaneously sent to the receiver, allowing the echoed data to be verified for collisions and resent if necessary.

RS-422

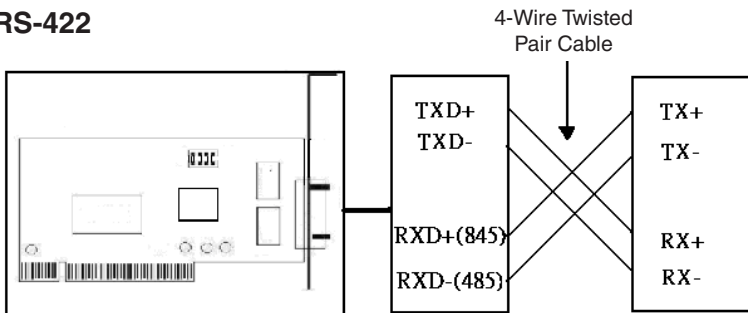

Please note: This card supports 4-wire RS-422 mode. In this mode, data is sent and received independently. As such, cross-over, twisted pair cable is required.

Specifications

	PCI2S485LP PCI2S485LP15
Bus Interface	PCI (5V) / PCI-X (3.3V)
Chipset	Moschip MCS9835CV
Number of Ports	1 x DB15F 2 x DB9M (via DB15 to DB9 breakout cable)
Max Data Transfer Rate	115.2 Kbps
Bits Data Framing Support	5/6/7/8/9
Supported Operating Systems	Windows [®] 2000/XP/Vista, Linux [®]

FCC Compliance Statement

This equipment has been tested and found to comply with the limits for a Class B digital device, pursuant to part 15 of the FCC Rules. These limits are designed to provide reasonable protection against harmful interference in a residential installation. This equipment generates, uses and can radiate radio frequency energy and, if not installed and used in accordance with the instructions, may cause harmful interference to radio communications. However, there is no guarantee that interference will not occur in a particular installation. If this equipment does cause harmful interference to radio or television reception, which can be determined by turning the equipment off and on, the user is encouraged to try to correct the interference by one or more of the following measures:

- Reorient or relocate the receiving antenna.
- Increase the separation between the equipment and receiver.
- Connect the equipment into an outlet on a circuit different from that to which the receiver is connected.
- Consult the dealer or an experienced radio/TV technician for help.

Use of Trademarks, Registered Trademarks, and other Protected Names and Symbols

This manual may make reference to trademarks, registered trademarks, and other protected names and/or symbols of third-party companies not related in any way to StarTech.com. Where they occur these references are for illustrative purposes only and do not represent an endorsement of a product or service by StarTech.com, or an endorsement of the product(s) to which this manual applies by the third-party company in question. Regardless of any direct acknowledgement elsewhere in the body of this document, StarTech.com hereby acknowledges that all trademarks, registered trademarks, service marks, and other protected names and/or symbols contained in this manual and related documents are the property of their respective holders.

Technical Support

StarTech.com's lifetime technical support is an integral part of our commitment to provide industry-leading solutions. If you ever need help with your product, visit www.startech.com/support and access our comprehensive selection of online tools, documentation, and downloads.

Warranty Information

This product is backed by a lifetime warranty.

In addition, StarTech.com warrants its products against defects in materials and workmanship for the periods noted, following the initial date of purchase. During this period, the products may be returned for repair, or replacement with equivalent products at our discretion. The warranty covers parts and labor costs only. StarTech.com does not warrant its products from defects or damages arising from misuse, abuse, alteration, or normal wear and tear.

Limitation of Liability

In no event shall the liability of StarTech.com Ltd. and StarTech.com USA LLP (or their officers, directors, employees or agents) for any damages (whether direct or indirect, special, punitive, incidental, consequential, or otherwise), loss of profits, loss of business, or any pecuniary loss, arising out of or related to the use of the product exceed the actual price paid for the product. Some states do not allow the exclusion or limitation of incidental or consequential damages. If such laws apply, the limitations or exclusions contained in this statement may not apply to you.